

## How to fabricate a N male and female calibration kit With arbitrary calibration data for VNWA 2 and VNWA3

### Preface:

I managed to borrow two N male HP calibration kit type 85032E, where the Agilent homepage provides the calibration data for both the male and female short, open and load calibration standards. These calibration data consist of the delays and the needed L and C coefficients to create the arbitrary calibration string for VNWA2 and VNWA3.

The data to be found on following link. <http://na.tm.agilent.com/pna/caldefs/PNA/85032BE.htm>

Below table is an extract from the link and brought here to explain how the arbitrary calibration setup for the VNWA is done. Any frequency dependant data for the load is not included, as not relevant, because the only information needed is the resistance defined as 50 ohm and the Loss being 0.7Gohm/Sec and not at all important for the VNWA calibration, due to the frequency range limited to 1.3GHz. Below is explained how the delays, L and C coefficient has to be understood.

Std No.	Label	Description	Connector	Sex	C0 F(e-15)	C1 F(e-27)/Hz	C2 F(e- 36)/Hz^2	C3 F(e-45)/Hz^3	Fmin (MHz)	Fmax (MHz)	Delay (Sec)	Loss (Gohm/Sec)	Z0 (Ohm)
2	OPEN -M-	Type N (50) male open	Type N (50)	MALE	62.14	-143.07	82.92	0.76	0	999000	1.74E-11	0.7	50
5	OPEN -F-	Type N (50) female open	Type N (50)	FEMALE	119.09	-36.955	26.258	5.5136	0	999000	0.00E+00	0.7	50
Std. No.	Label	Description	Connector	Sex	L0 H(e-12)	L1 H(e-24)/Hz	L2 H(e-33)/Hz^2	L3 H(e-42)/Hz^3	Fmin (MHz)	Fmax (MHz)	Delay (Sec)	Loss (Gohm/Sec)	Z0 (Ohm)
3	SHORT -M-	Type N (50) male short	Type N (50)	MALE	0	0	0	0	0	999000	1.78E-11	2.1002	50.209
6	SHORT -F-	Type N (50) female short	Type N (50)	FEMALE	0	0	0	0	0	999000	9.30E-14	0.7	49.992

These above data is defined for calibration plane identical to the N connectors reference plane. Below is given explanation for the open male standard being the example used.

For the open male standard notice the delay 1.74E-11 seconds, which correspond to 17.4ps and it is the one way delay. For the VNWA calibration setting you must be entered twice that value, as a negative delay, equal to -34.8ps. The C values is the relevant data to simulate the frequency dependance (end point radiation) from the open center conductor. C0 is the frequency inependant fringe capacitance of 0.06214pF (equivalent to a one way delay of 3.107ps calculated by dividing the C0 value in fF by 20) , and the C1, C2 and C3 is frequency dependant capacitive elements in Farad, divided with the frequency in Hz for C1, frequency in Hz squared (^2) for C2 and frequency in Hz triplicated (^3) for C3.

Thus the formula in VNWA Arbitrary calibrated settings is quite simple to express as admittances (Y), because these capacitive elements is summed together due to be in parrallel. Rember that for admittance the sign for C is positive (like for S parameters) but negative if expressed as impedance (Z).

I have been there 😊.

For the expression  $i \cdot w$ , the  $i$  equal to imaginary data indication ( same as  $j$  ) and  $w$  is equal to  $2 \cdot \pi \cdot \text{freq}$  so the complete expression is:  
 $i \cdot w \cdot (62.14e-15 - (143.07e-27/f) + (82.92e-36/f^2) + (0.76e-45/f^3))$  (just copy and paste into the VNWA arbitrary calibration setting) and below is seen the complete entry for the VNWA calibration settings

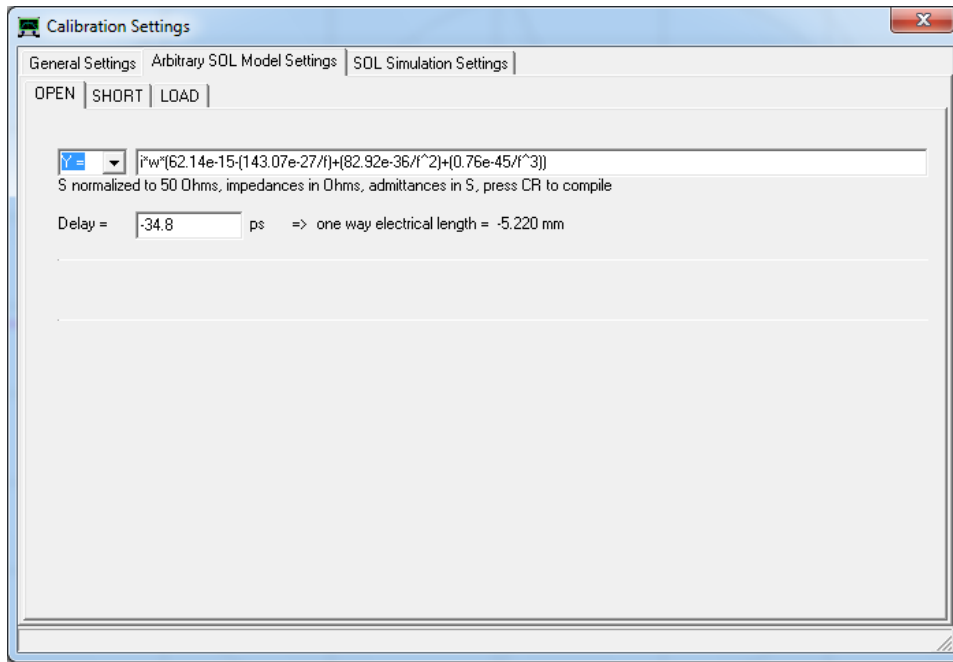

Above the settings for N male open

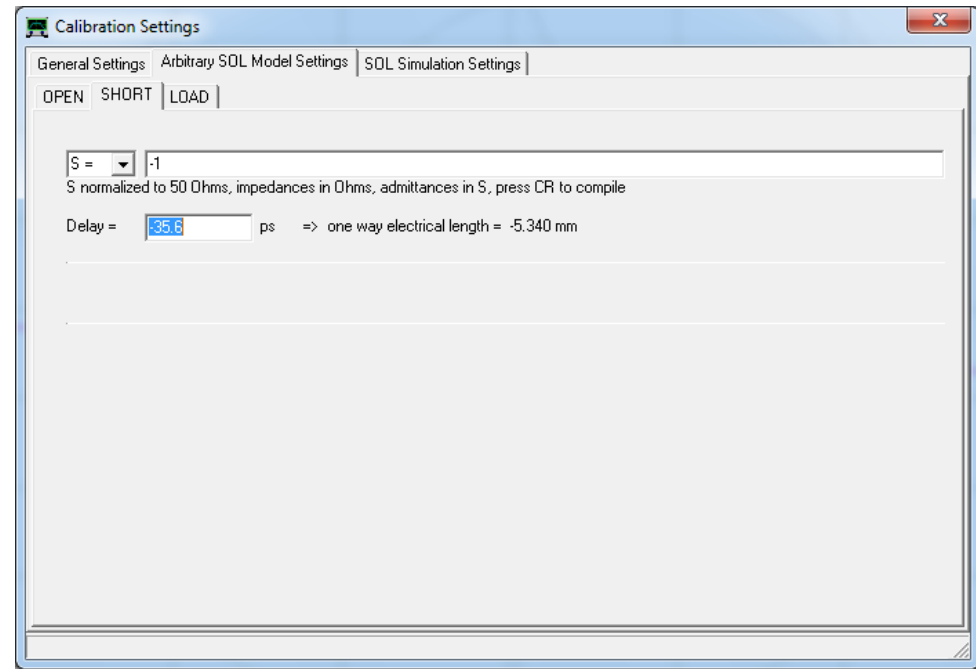

Above the setting for N male short as only a delay  $2 \times 17.8 \text{ ps} = -35.6 \text{ ps}$  is defined (no L0, L1, L2 and L3). Remark the delay is negative.

Note.! If you do not want to use arbitrary calibration but ordinary simple model the the C0 value must be added to the fixed delay being  $2 \times (17.8 + 3.107) \text{ ps} = -41.814 \text{ ps}$

**A notice of warning !!!**

The data for Std. No 5 - the open female calibration standard - contains a C0 value of  $119.09 \text{ fF} = 5.9545 \text{ ps}$  which as well for the C1, C2 and C3 values is pending the use of a center conductor extender. Such a device is not normally available/supplied if you purchase a HP 85032B/E clone kit on e.g. e-bay (as I did) and that problem is dealt with later in this report, how to handle, and still be able to use the arbitrary calibration data for the female calibration standard. It is only really relevant if you want to create ultimate calibration and is going beyond the 1GHz range. You will be shown how to calibrate without use of the center conductor extender. However I have made a center conductor extender based on some simulation (as being shown) and when using the arbitrary calibration the string for copy and paste is:

$$i \cdot w \cdot (119.09e-15 - (-36.955e-27/f) + (26.258e-36/f^2) + (5.5136e-45/f^3))$$

Using simple model the delay is  $2 \times (0.00 + 5.9545) \text{ ps} = 11.909 \text{ ps}$

## How did it all start

I purchased long ago, from Ebay, a complete N male and female open and short calibration kit, which to my pleasant surprise, I later discovered were clones of the HP85032BE kit. Below I show some pictures of these open and short calibration standards.



Rear view male and female short and open



front view male and female short



front view male and female open

As seen the open calibration standard just consist of a 7mm drilled hole. The female short calibration standard is just a shorting center bushing standing out from the reference plane, which when mated with a N male adaptor ensures connection to the inner conductor and engagement to the reference plane of the N male adaptors outer conductor, of internal diameter 7mm, and thus provide a delay of 0 pS (actually 0.09pS if an exact clone the HP85032/BE).

The male short calibration standard is connecting to the mating female adaptor center conductor and its outer conductor, of internal diameter 7mm is engaging to the N female adaptors reference plane, thus will the delay be determined by how deep into the outer conductor the shorting disk is positioned on of the male short calibration standard. It depth measured to be 5.34mm which multiplied by 3.333333 (speed in air) results in a delay of 17.8ps, exactly like the Std. no 3 of the HP 85032/BE. The mated center conductor has a diameter of 3.04mm which combined with the hole of 7mm provides a Z0 of 50 ohm. A direct copy and home made set of male and female standards is is not an easy task, without having fine machinery, but there is **a simpler way** to do it, **still producing a well defined male and female open and short calibration standards, for VNWA3 and VNWA2 use, and which is reproducible.**

The basic simplicity of the design as shown on the pictures indicates it must be able to fabricate homemade N calibration standards, and as having access to 2 pc. male HP85032E calibration kits, I can calibrate my VNWA3 + VNWA2 and measure both the Ebay clone kit, as well as my own homemade "clones of the clones and clones of HP85032/BE", and from saved Touchstone S11 files mathematically derive a set of coefficients, (if needed at all) fully useable for arbitrary calibration of the VNWA2 and VNWA3. I have done such coefficient deriviations earlier for both Rosenberger and Amphenol Connex SMA male/female calibration standards, so I have proven it works as expected.



25.2 mm End to End

31.7 mm end to end when mated  
30.6mm for the outer conductor  
of inner diameter of 7 mm

The Essential information for this Sideview picture is the length for the open male and female calibration standards and as shown. It will be proven that the length is not critical, but for those which plan to use/test at frequencies beyond the VNWA range of 1.3GHz they are copied as exact as possible.

Side view for the male and female open and Short

Regarding the load standard I strongly recommend to purchase a commercial Load. I have purchased a couple and in particular the Radial N male load (Radial part nr. R404240000 from Farnell (part nr. 4196624) is very close in characteristic to the HP85032E Load standard. I have also designed a homemade load which is tested to be OK as well for the VNWA frequency range. More on that later.

The numerous other N male loads are from R&S, Huber Suhner and a very accurate HP inline attenuator which, when loaded on the output with 50 ohm also act as a good load. I will provide more data in the last section of this report.



## How to understanding a calibration standard from a physical point of view.

Before we start looking on how to create a homemade N male and female calibration kit, let us first understand what happens from a physical perspective point of view.

As an example lets examine the N male calibration standard which is just a cylindric out conductor (a hole) of diameter 7mm when fitted to the female mating connector at the end of a testcable or fitted to a N female on the front of the VNA/VNWA, by using a free and very excellent Finite Element Method program called Femm.

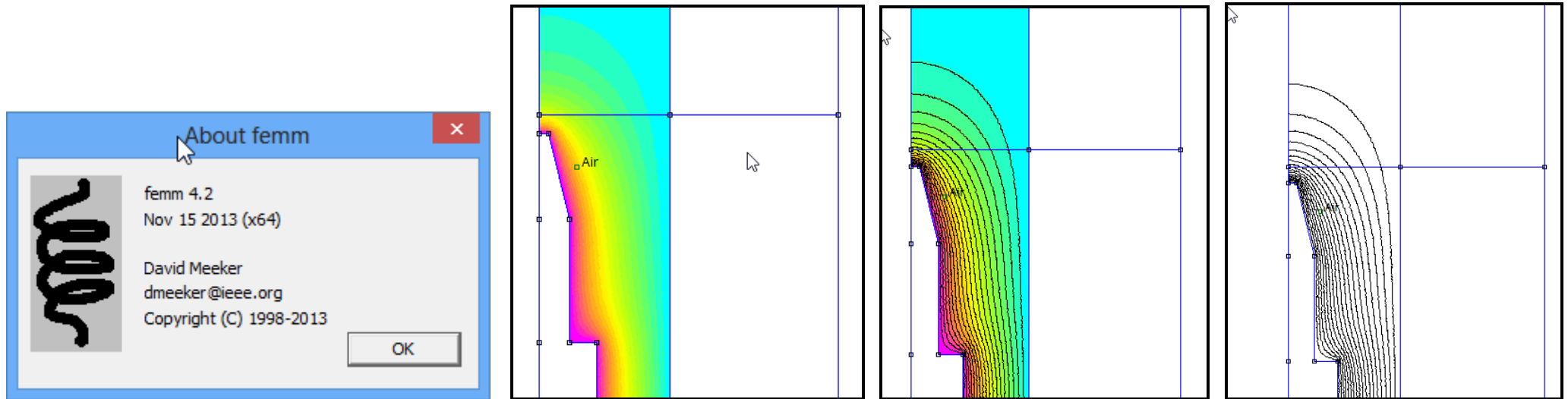

Varoious representations of the simulations is possible, but including the equipotential lines, which is very illustrative in full screen mode, is however not practical to apply when images scaled down, as the lines melt together and as well hiding the material indicators, such as air shown in the examples. Conclusion ...lines avoided in this report.

Next step:

For simulating the assembly of N male calibration standard and the mating female N adaptor we need to find and define the mechanical dimensions.

For that purpose a study of the Huber Suhner, Rosenberger, Radial and Amphenol connex homepage for connectors showed they all were very identical as follows.

Manufacturer specific length of the 50 ohm transmission line  
Length typical from 3 to 6 mm  
and not important for usage

Air filled section which form a 50 ohm transmission line in combination with the center bushing.  
Diameter 7mm  
(6.98 to 7.02mm)

PTFE filling behind the 50 ohm air transmission line.  
Epsilon 2.05 for the PTFE.  
For inner conductor diameter 3.04mm  
a diameter of 10mm = 50 ohm  
Diameter not provided by manufacturer but measured

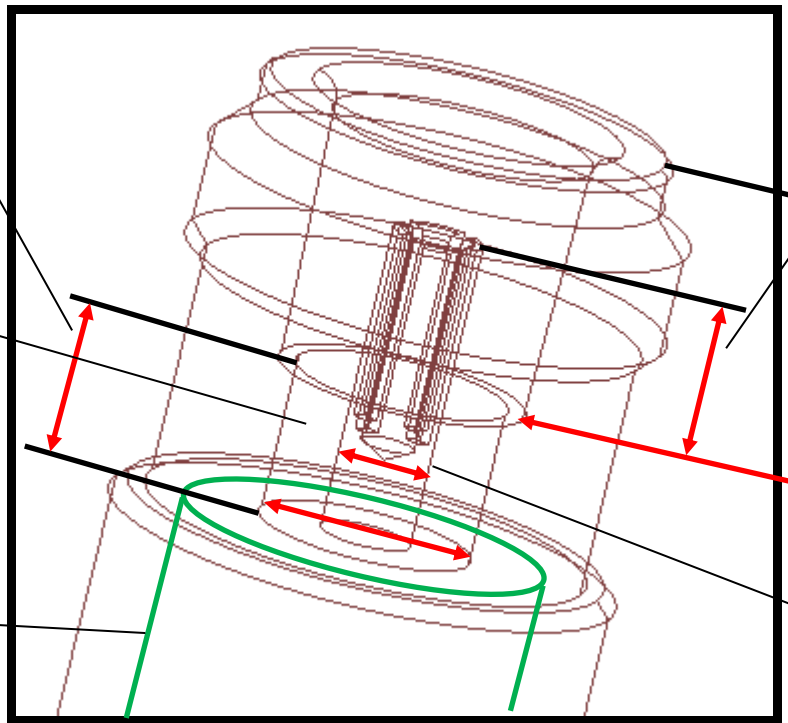

Extrusion of center conductor from reference plane  
5mm  
(4.75 to 5.25mm)

Distance from reference plane to front  
9.12mm  
(9.05 to 9.19mm)

Reference plane

Center conductor diameter 3.04mm  
(3.01 to 3.05mm)

Outside diameter not important but typical 16mm

These dimensions used for the simulation in Femm, and to understand below pictures, the assembly is shown in vertical position with only half of the adaptor shown with centerline to the left side. The mating connector (N female) shown below and the male open calibration standard above. If you do not understand right away the carry on reading.

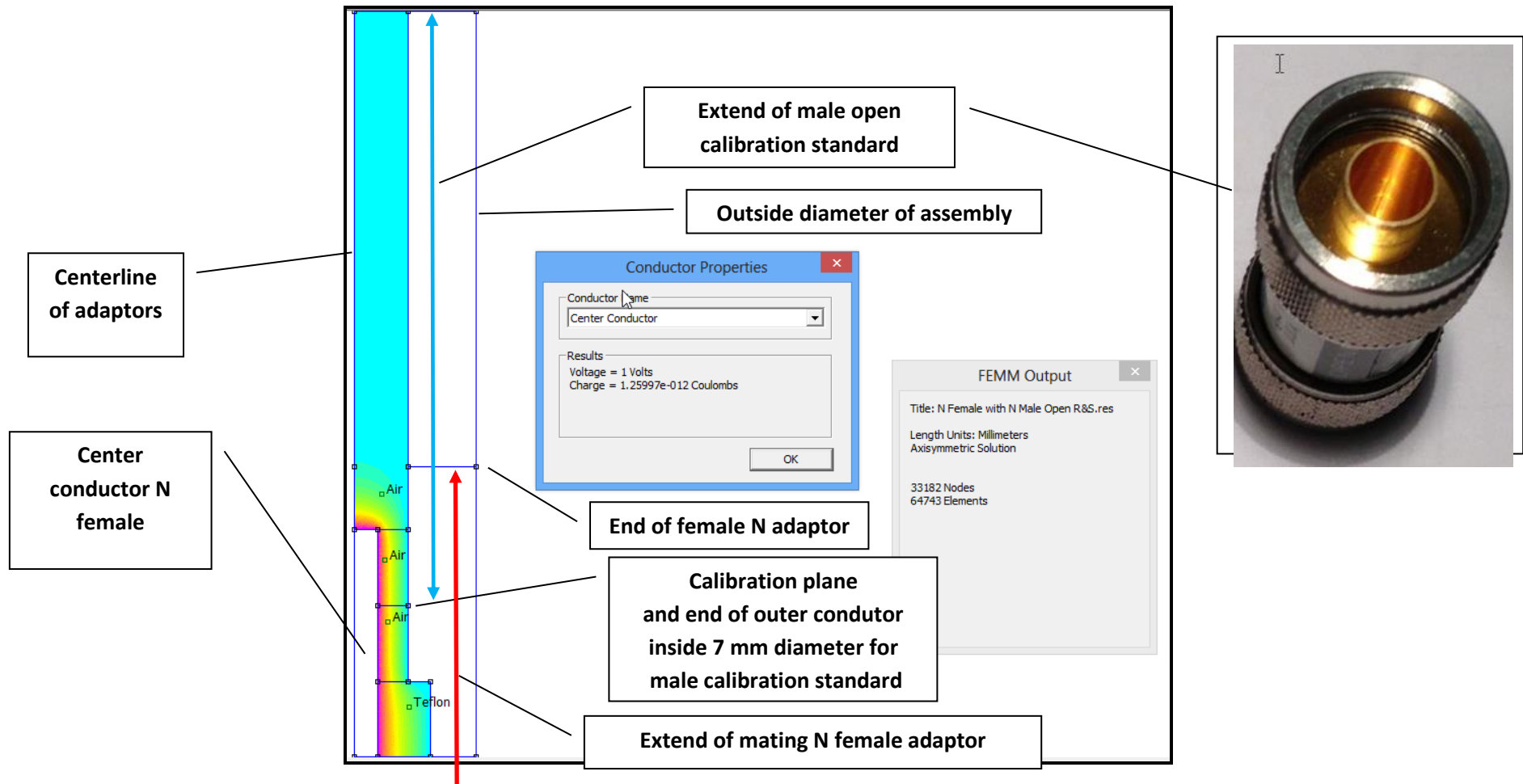

In the picture is shown the measured Charge at 1 Volt which is identical to the capacity  $1.25997 \text{ pF}$  or  $1259.97 \text{ fF}$ , which equals to a delay of  $1259.97/20 \text{ ps} = 62.9985 \text{ ps}$ . This is not the entire delay of the N female adaptor as in the simulation is only taken an arbitrary length with teflon. The section of interest is the delay above the reference plane which is the delay for the 5 mm long center conductor, and the fringe capacitance at the end of the center conductor, which you can see is intruding into the male open calibration standard some 5 mm from the tip of the center adaptor. We will now determine the delay of the center adaptor from reference plane incl. fringe capacitance and the center adaptor from reference plane on its own. The difference will be the fringe capacitance contribution.

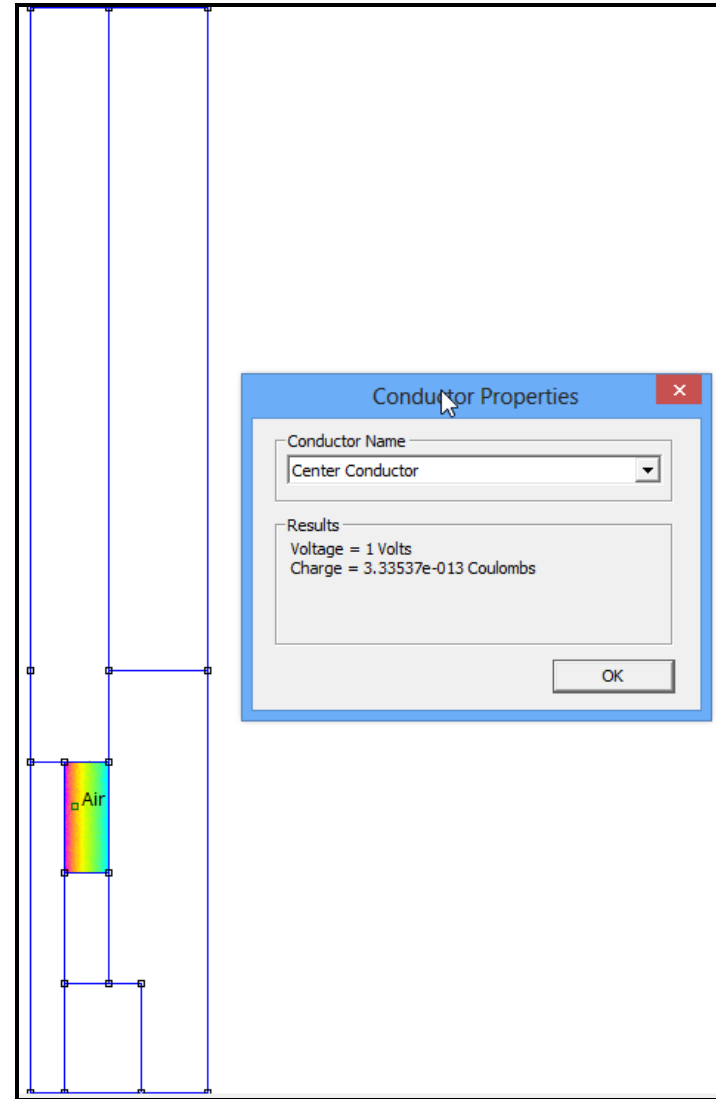
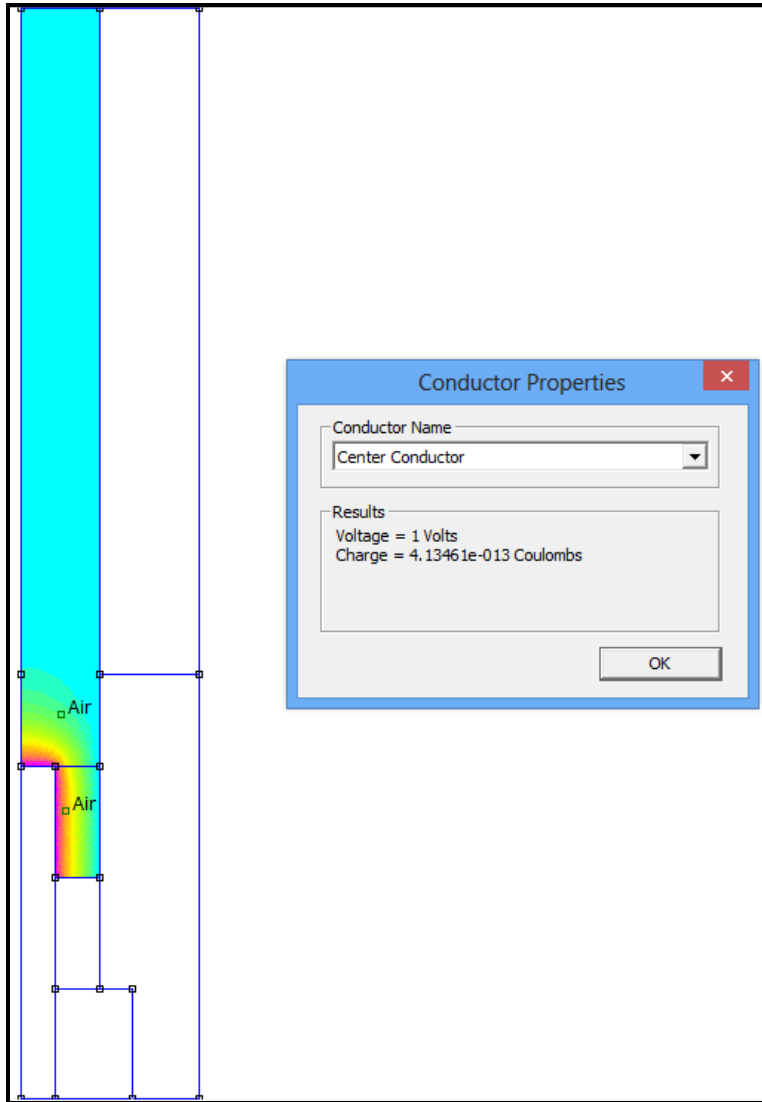

The delay for center adaptor incl. fringe is  $413.461\text{fF}/20 = 20.673\text{ps}$  and for the center conductor alone  $333.537\text{fF}/20 = 16.667\text{ps}$ . Thus the fringe capacitance alone is  $4.006\text{ps}$  or by subtracting the charges we get  $413.461 - 333.537 = 79.924\text{fF}$ .

We will now compare these calculation with the data provided for the HP 85032BE kit which in below schematic is the Std. No. 2

Std No.	Label	Description	Connector	Sex	C0 F(e-15)	C1 F(e-27)/Hz	C2 F(e-36)/Hz^2	C3 F(e-45)/Hz^3	Fmin (MHz)	Fmax (MHz)	Delay (Sec)	Loss (Gohm/Sec)	Z0 (Ohm)
2	OPEN -M-	Type N (50) male open	Type N (50)	MALE	62.14	-143.07	82.92	0.76	0	999000	1.74E-11	0.7	50
5	OPEN -F-	Type N (50) female open	Type N (50)	FEMALE	119.09	-36.955	26.258	5.5136	0	999000	0.00E+00	0.7	50
Std. No.	Label	Description	Connector	Sex	L0 H(e-12)	L1 H(e-24)/Hz	L2 H(e-33)/Hz^2	L3 H(e-42)/Hz^3	Fmin (MHz)	Fmax (MHz)	Delay (Sec)	Loss (Gohm/Sec)	Z0 (Ohm)
3	SHORT -M-	Type N (50) male short	Type N (50)	MALE	0	0	0	0	0	999000	1.78E-11	2.1002	50.209
6	SHORT -F-	Type N (50) female short	Type N (50)	FEMALE	0	0	0	0	0	999000	9.30E-14	0.7	49.992

The delay for the center conductor is 17.4ps (simulation was 16.667ps) and the static fringe capacitance C0 is 62.14fF (simulation was 79.924fF). The delay difference of 0.733ps correspond to - 0.22mm displacement relative HP and the fringe capacitance difference 17,784fF or + 0.889ps compared to HP resulting in a netto difference of 0.67mm. Just a small adjustment of the center conductor length will impact the delay e.g. extending within the tolerances 4.75 to 5.25mm with increase the delay from 16.667ps to 17.5ps. The Femm accuracy is supposed to be within + - 0.2% and further trimming possible by decreasing the mesh size.

**Anyway the issue was not to prove the accuracy but to facilitate the physical understanding and demonstrate that if we produce a homemade N male open calibration standard, the only requirement is to provide a tubular diameter of 7 mm of adequate length and we can fully justify to use the HP data incl. the C0, C1, C2 and C3 data and trust the result. What else ☺ .....**

**But what about using the female N adaptor without the N male calibration standard for calibration ?**

As it is not the N male calibration standard adaptor which determine the delay but almost only the mating N female adaptor we might use that on its own. Below is shown the simulation and the result is a difference of (20.673 – 20.69)ps = -0.017ps so nothing.

The total charge is 413.735fF and without Fringe capacitance it is 333.509fF (as seen before although a bit smaller due to a finer mesh in the simulation) Then the total delay is  $413.735/20 = 20.69\text{pS}$  where the fringe capacitance accounts for  $4.01\text{pS}$  ( $413.735-333.509$ )/20. We shall later on see how that works when comparing to the “official calibration method” for the VNWA up to 1.3GHz

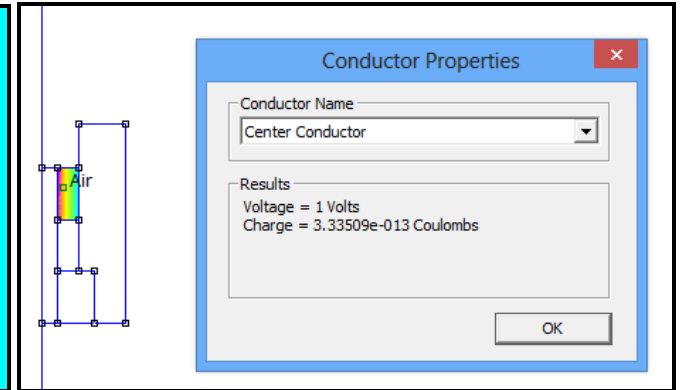
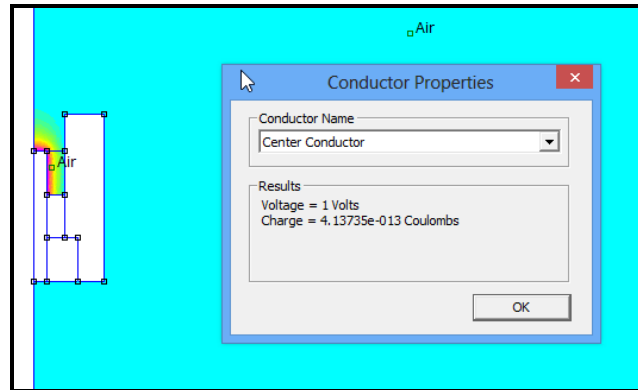

Now we shall repeat the process for the N female open calibration standard mating with the N male adaptor of which there are two basic types

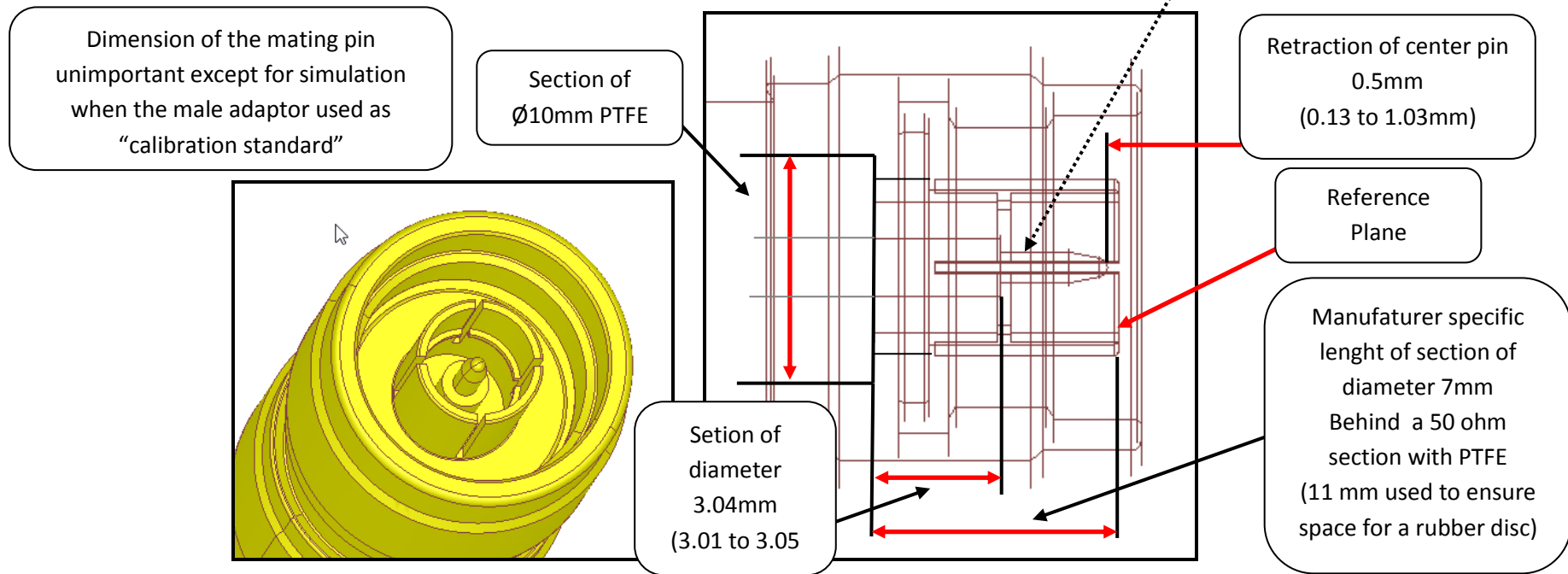
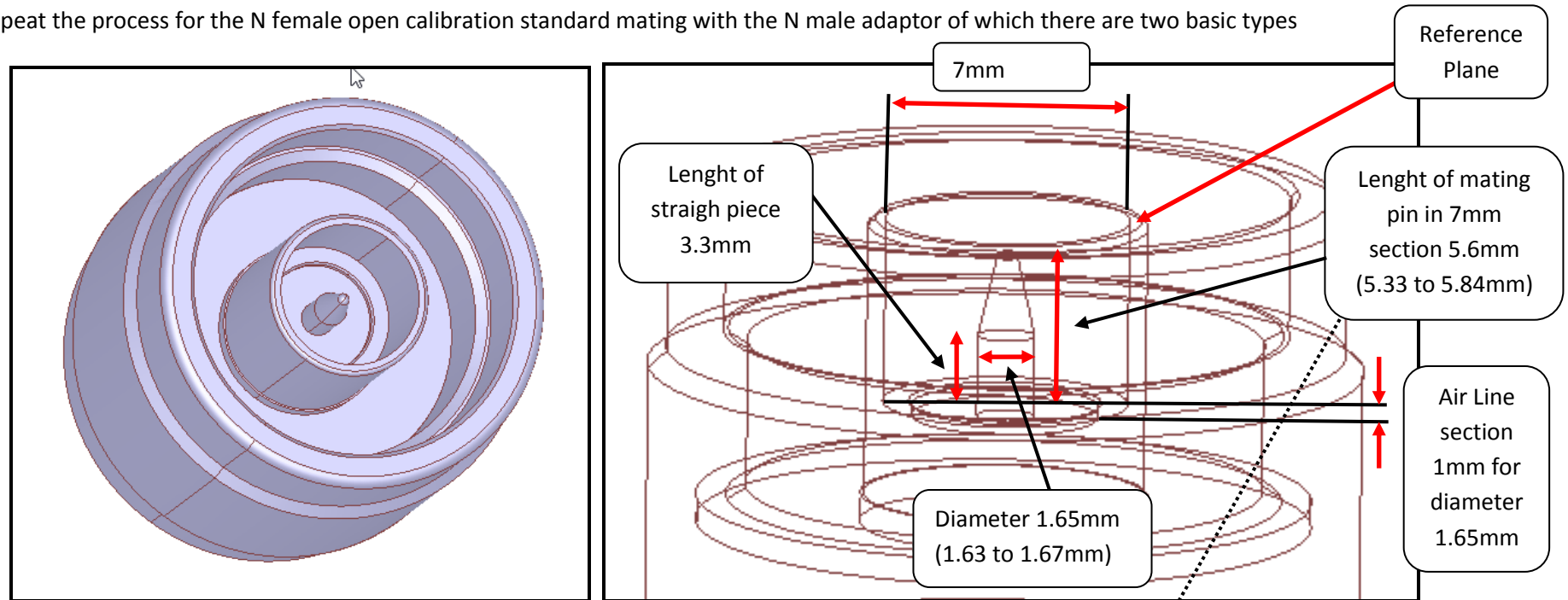

Simulation of the N male adaptor without the N female calibration adaptor.

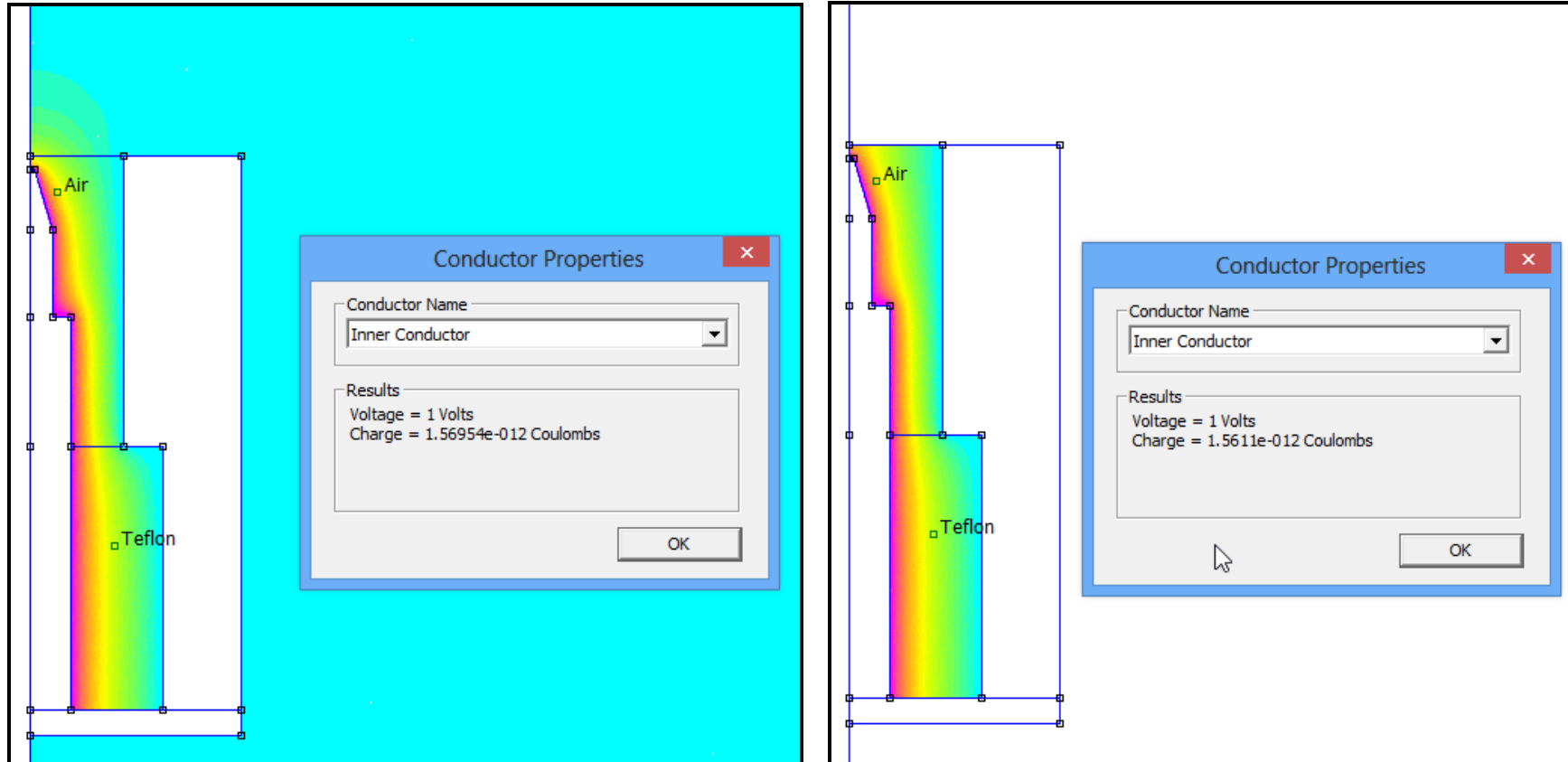

The entire charge is 1569.54fF (left image) and below the calibration plane (right image) the charge is 1561.1fF. Then the difference is the fringe capacitance of **8.44fF** and by division of 20 is correspond to a delay of **0.422ps**. Remember that by definition there is no fixed delay as the electrical calibration plane is identical to the mechanical reference plane for a male N adaptor.

Next follows the simulation when the N female calibration adaptor fitted to the mating N male adaptor:

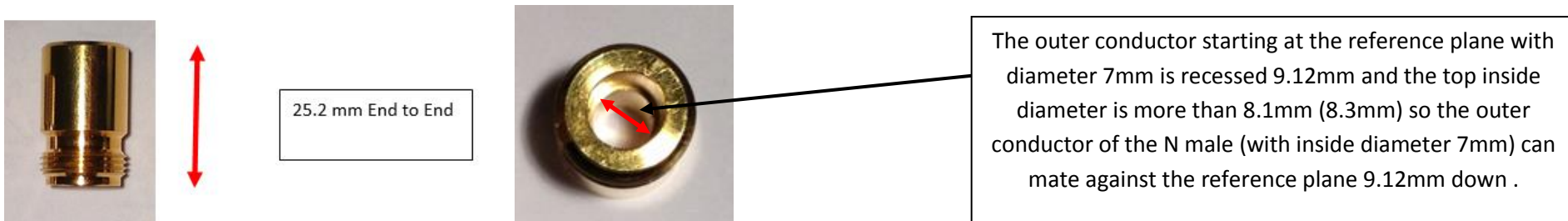

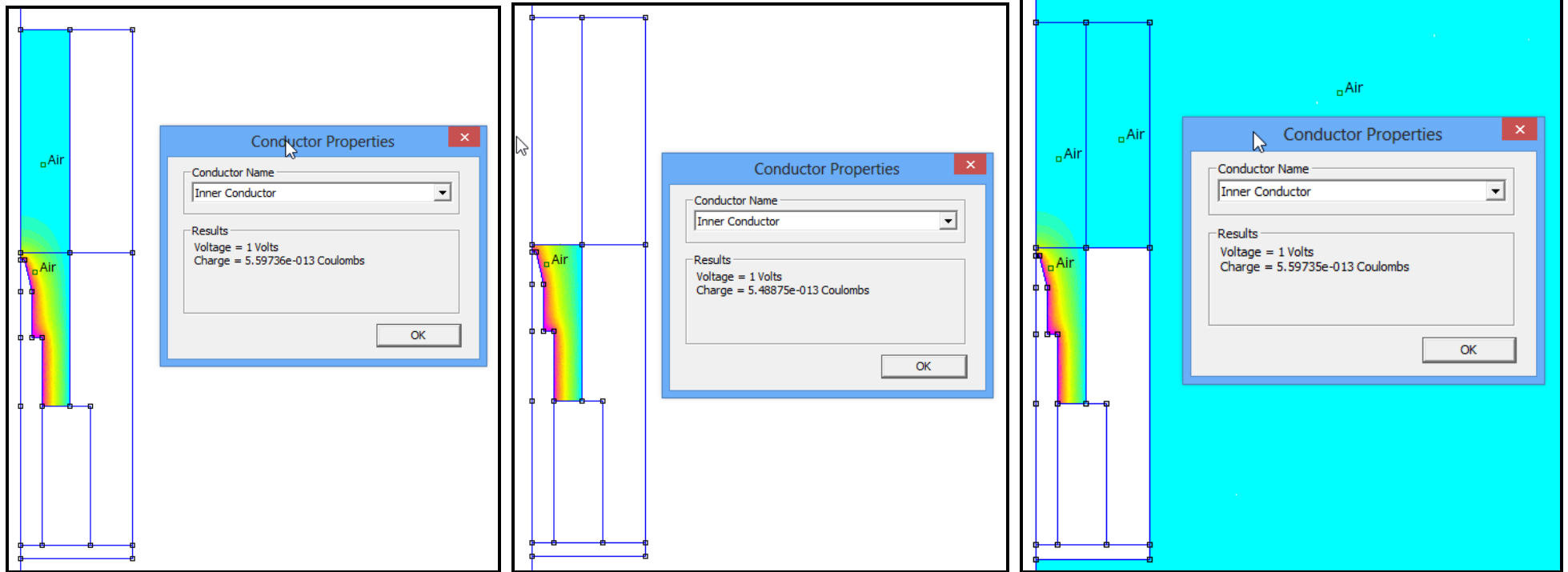

The entire charge is 559.736fF (left image) and below the calibration plane (right image) the charge is 548.875fF. Then the difference is the fringe capacitance of **10.861fF** and by division of 20 is correspond to a delay of **0.543ps**. Remember again that by definition there is no fixed delay as the electrical calibration plane is identical to the mechanical reference plane for a male N adaptor. The impact on the fringe capacitance when mounting the N female calibration adaptor is next to nothing only 0.001fF = 0.00005ps (559.735-559.736)fF corresponding to a displacement of the calibration by 0.0000015mm. So no need for the N female open calibration adaptor apparently or what ??

We have to go back to the HP 85032/BE kit table to see how the conditions are when calibrating with the female open standard which is Std. No 5

Std No.	Label	Description	Connector	Sex	C0 F(e-15)	C1 F(e-27)/Hz	C2 F(e-36)/Hz^2	C3 F(e-45)/Hz^3	Fmin (MHz)	Fmax (MHz)	Delay (Sec)	Loss (Gohm/Sec)	Z0 (Ohm)
5	OPEN -F-	Type N (50) female open	Type N (50)	FEMALE	119.09	-36.955	26.258	5.5136	0	999000	0.00E+00	0.7	50

The delay as expect 0.00E+00 but the Fringe Capacitance C0 is 119.09fF ?? What is the explanation to that. See below why...

The Explanation is quite simple (when you first find it ☺) as the user manual for the HP 85032BE has a picture showing a center conductor extender, which is part of the N female calibration kit. There is no information how long this center conductor extender is, but simulations to follow is resulting in 6.7mm. This center conductor extender is sitting at the of an isolated shaft, ensures the diameter is 3.04mm all along and this to ensure proper operation for the entire frequency span up to some 6 GHz so the C1, C2 and C3 coefficient is valid to use. The idea is probably to extend it to the calibration reference plane but I do not know if that is true, but in that case it should be about 1 mm shorter. I made myself a center conductor extender as show on the picture to the right 6.7mm long. For VNWA frequencies up to 1.3GHz it is hardly necessary to do anything but just use the fringe capacitance delay of 0.543ps as found above and use no extender. That will be tested and documented later in this report.

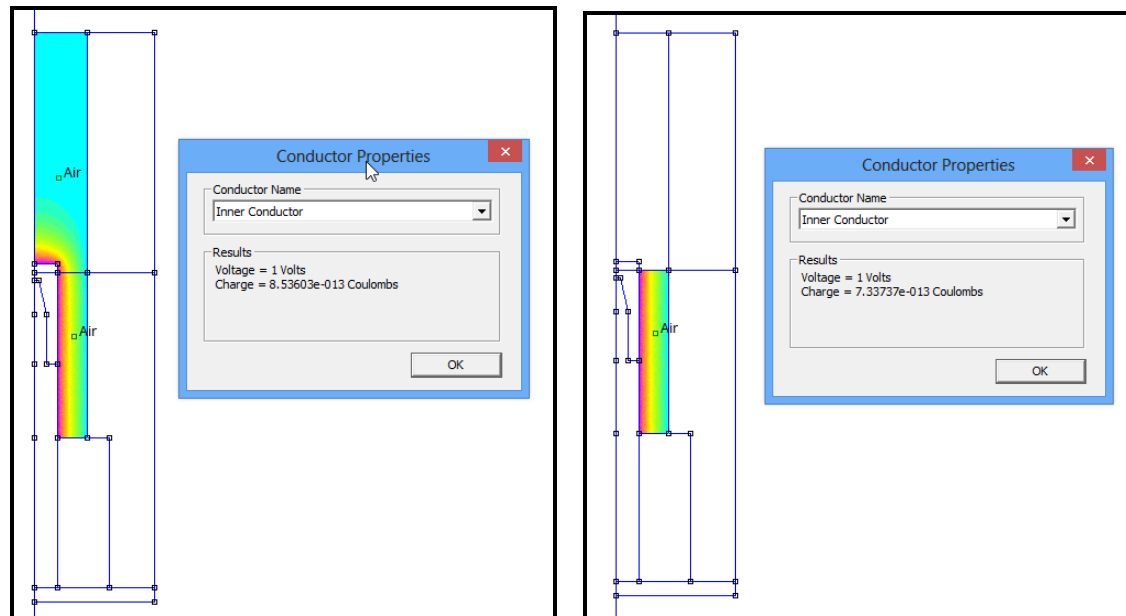
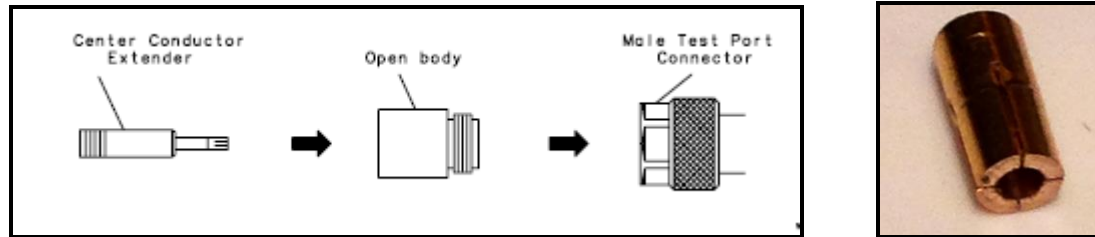

The entire capacity is 853.603fF and with the fringe capacitance above the calibration plane 733.737fF . Difference is 119.866fF equivalent to the HP figure for C0 of 119.09fF. Simulation of the fringe capacitance above the calibration plane is 119.163fF. So the fringe capacitance delay is  $119.866/20 = 5.99ps$  to be used as - 6ps or  $-(2 \times 6)ps$  in the calibration setting for VNWA, when using the center conductor extender but without applying arbitrary calibration where C0 C1, C2 and C3 comes into force. That concludes all the simulation as there is no point in examine the other N male type and as the short calibration standards are straight forward and will be dealt with in the next section.

**Let get started with the fabrication of the homemade N male short open and load calibration standard**

It all started with the following part from Aphenol Connex Part No. 172260-10 which I aquired cheaply from Ebay

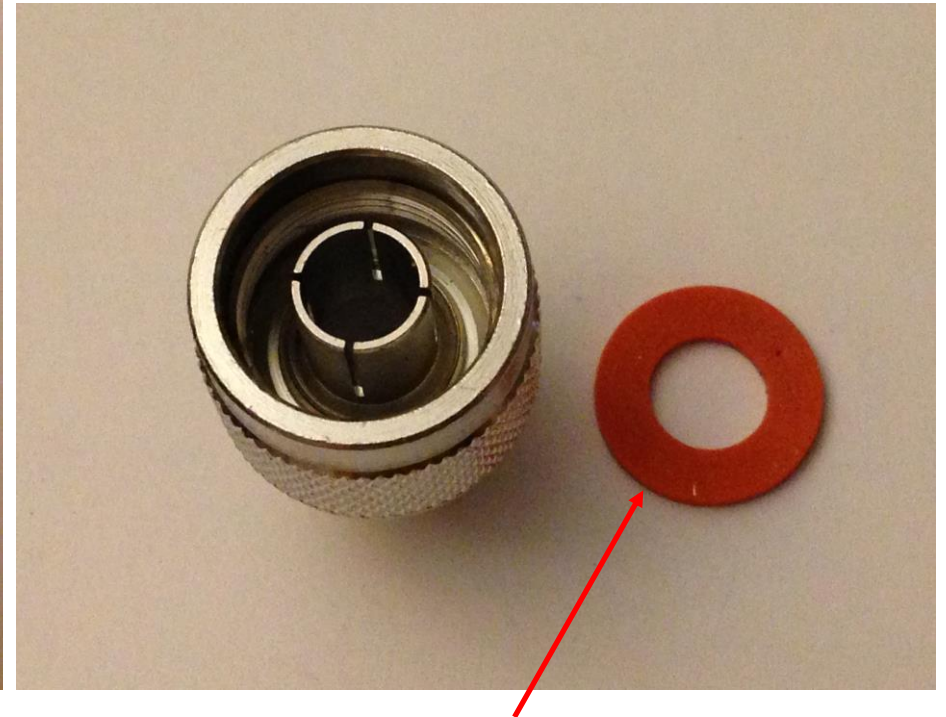

These adaptors are well suited for the production of the male short and open calibration standards. I have permanently removed all rubber disk inside the adaptors used

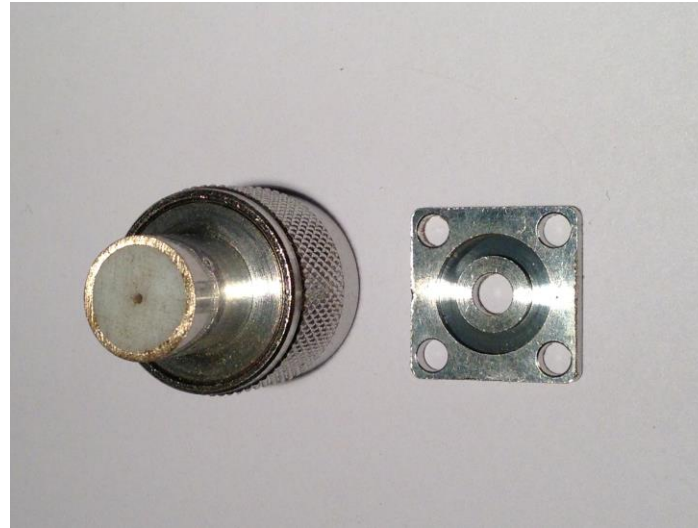

At first we need to remove the center conductor as shown on the left picture in a vice using a 1.5mm rod and a long 5mm aluminium/brass tube with an inside diameter of 3mm. Next jigsaw the endplate of the adaptor and grind it clean flat.

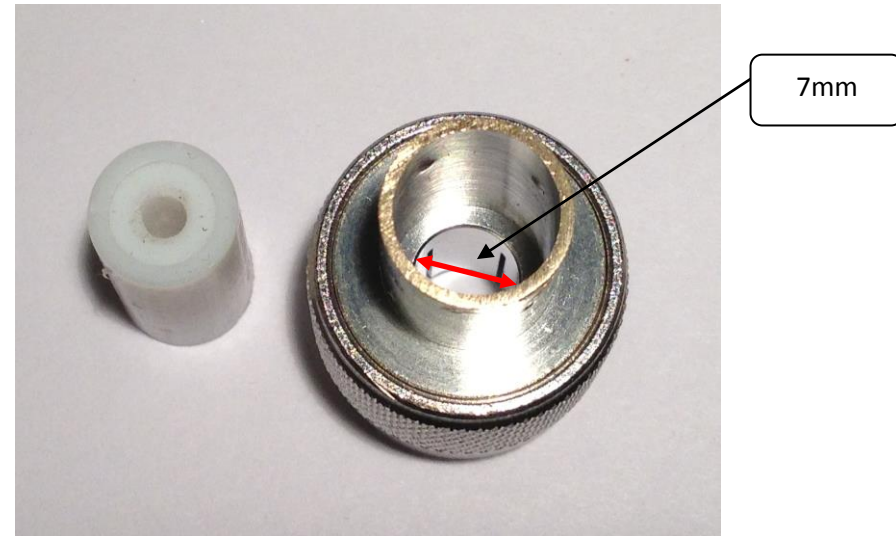
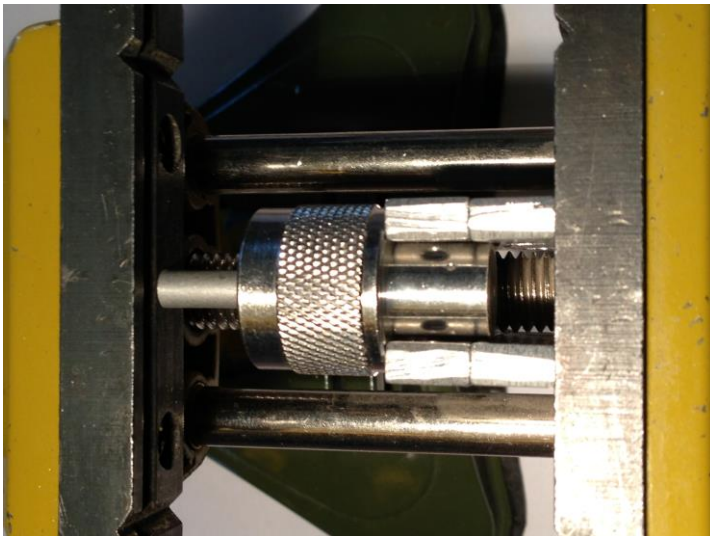

In a vice press out the PTFE bushing as shown, using a mm aluminium/brass tube with inside diameter 3mm. Now we have a clean adaptor with a view down to the 7mm diameter hole to form the open and short calibration adaptors controlled environment with inside diameter of 7mm.

Reference  
Plane

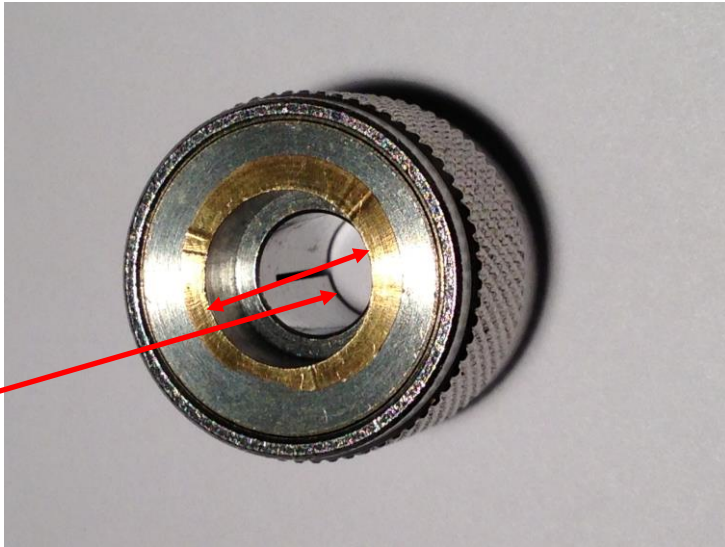

You may grind/mill the adaptor down as shown on left picture (or leave as is but it is beneficial to grind it down to just above the ensurface) and then find a piece of 10mm Cu tubing used for household water plumbing with a wall thickness of 1.5mm and cut a thin longitudinal slot to adjust the inside diameter to 7 mm when the edges of the slot is pressed together. Trim the outside diameter so it can be pressed into the adaptor against the rim where the inside 7 mm diameter starts and use the vice for a firm assembly. The Length from the calibration plane to end of the Cu tube is 32mm. Solder a small disk at the end of the Cu tube and close the slot by a small amount of solder. The male open calibration standard is now finally made as a HP clone. **You may check the inside depth from the reference plane to the bottom to be 32mm**

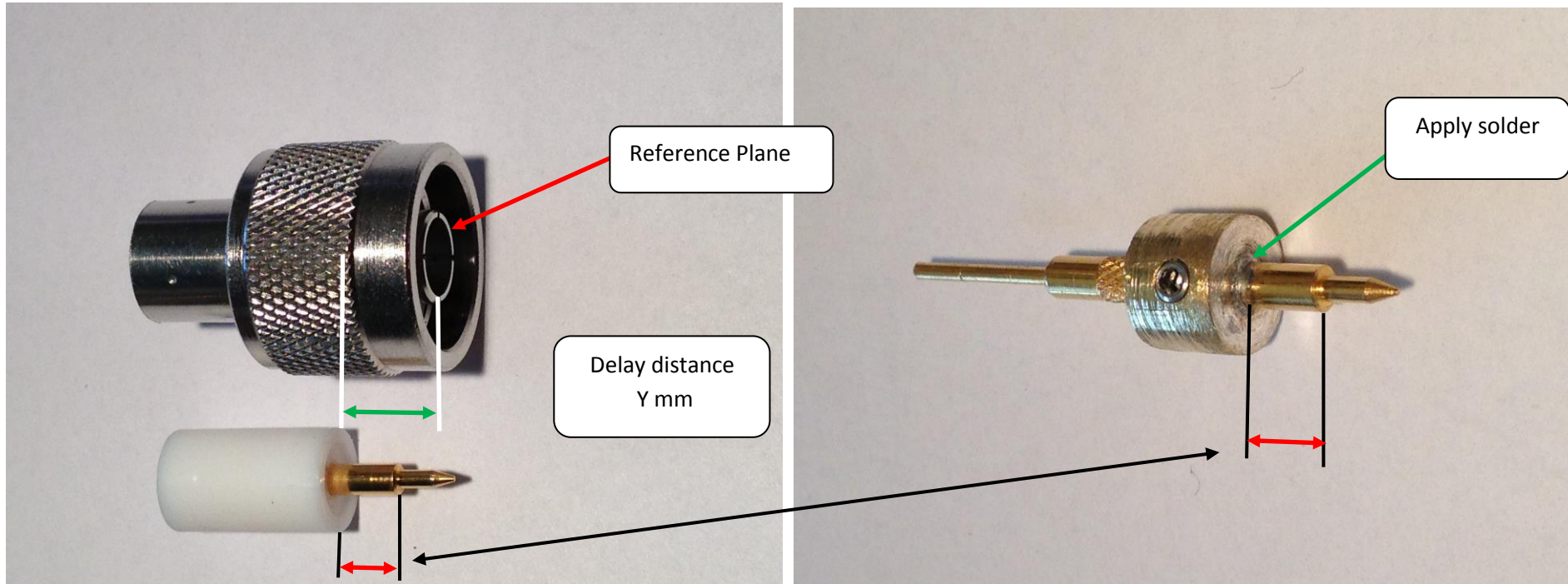

Produce a second adaptor where you also cut the center conductor when jigsaw'ing the endplate off and use a vise as shown above to remove the PTFE insert with the center conductor still fitted.

**Measure and note the distance shown accurately** as needed for ensuring the center conductor is brought back to its original position.

Also measure the delay distance inside the adaptor very accurate to Y mm. **The delay in ps is Y mm multiplied with 3.33333...**

The PTFE bushing from the production of the male open standard is used for the next steps.

Produce a shorting disk as shown on the right picture with outside diameter 9.9mm (or what diameter your adaptor might have) for being a press fit into the empty adaptor. I have drilled a 2mm hole for a 2.5mm thread and inserted a small hex screw to adjust and fix the distance to the same as measured on the PTFE unit on left picture. Use minimum of solder and cut away with a scalpel the excess solder.

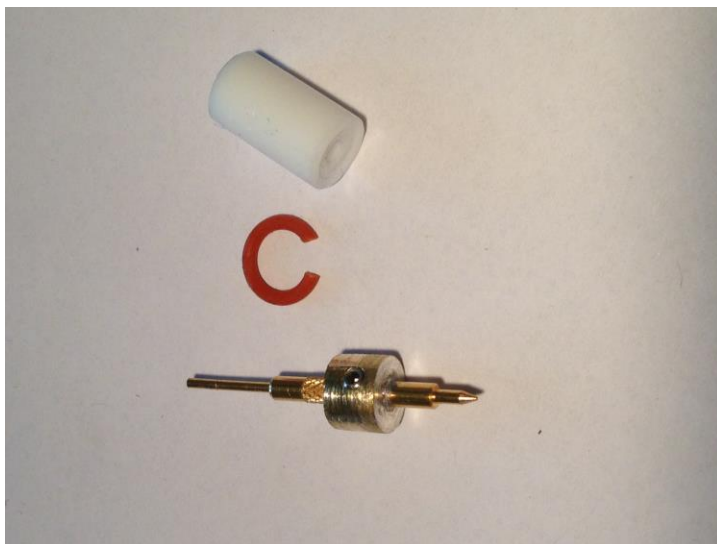

Cut a section of the surplus O-ring (to maintain pressure on the shorting disk) and the parts on the left picture now ready to be inserted into the empty adaptor

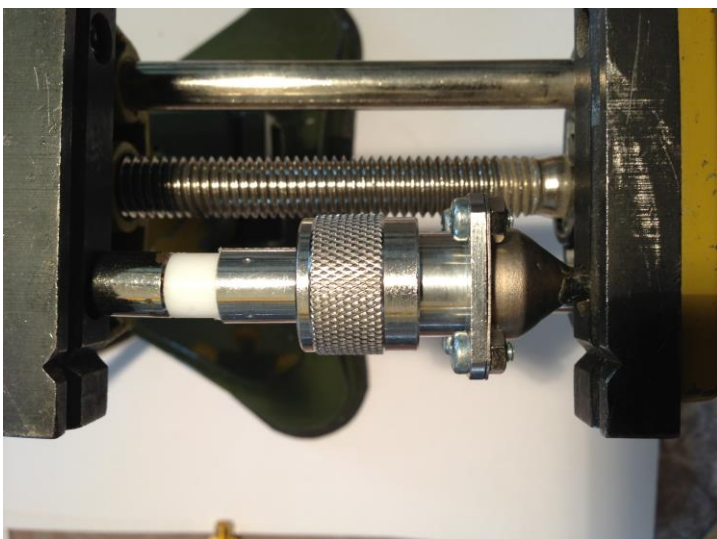

Mount the adaptor on a N female adaptor as shown above and use the vice to press the PTFE insert in place and while still under pressure drill a 2.5mm hole for each 90 degree and cut 3mm thread. Do not drill into the center conductor. Mount the 4 screw and take it apart for inspection and control measurements of the shorting disk depth from the reference plane although it should not be needed. That was the production of the male short calibration standard.

Much the same way is the femal open and short calibration standards made. The pictures are quite illustative. Again for the open standard a tube of inside 7 mm diameter is prepared for a pressfit into the empty adaptor. The total lenght of the tube and the distance to the reference plane is 16.12mm (23.24mm from front to end). Clone of Clone !!!! Please note the combined short and open shown on the left picture is exerimental, as the open is shorted with a disk for finding out if the caracteristics is influenced at all. Basicly it should be a advantage for very high frequencies. More on that later. Also very important is to measure and note the distance from end of PTFE to end of center conductor when the PTFE insert is pressed out in a vice with the center conductor still fitted. This distance needed for mounting and soldering the center conductor to a shorting disk so it is exactly in the same position inside the adaptor when assembled.

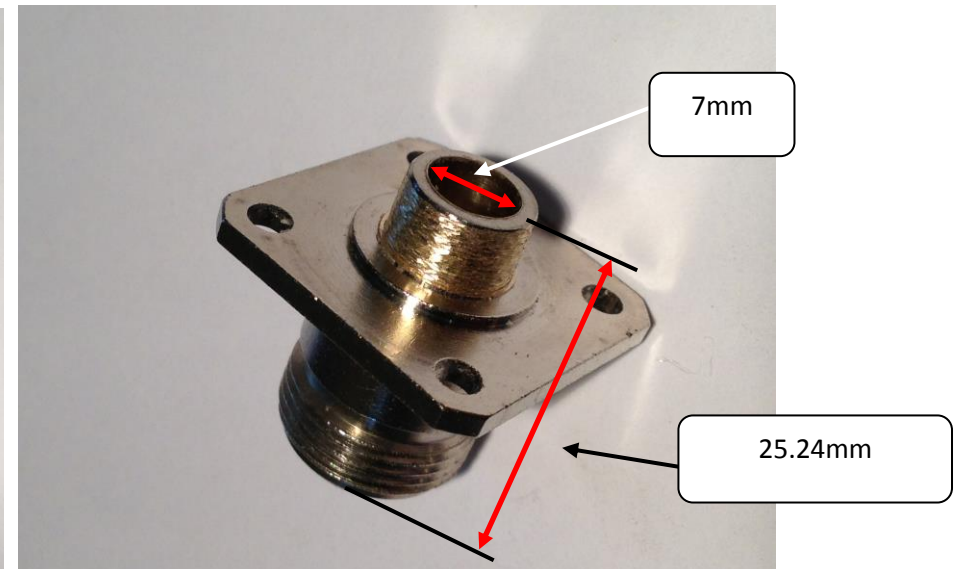
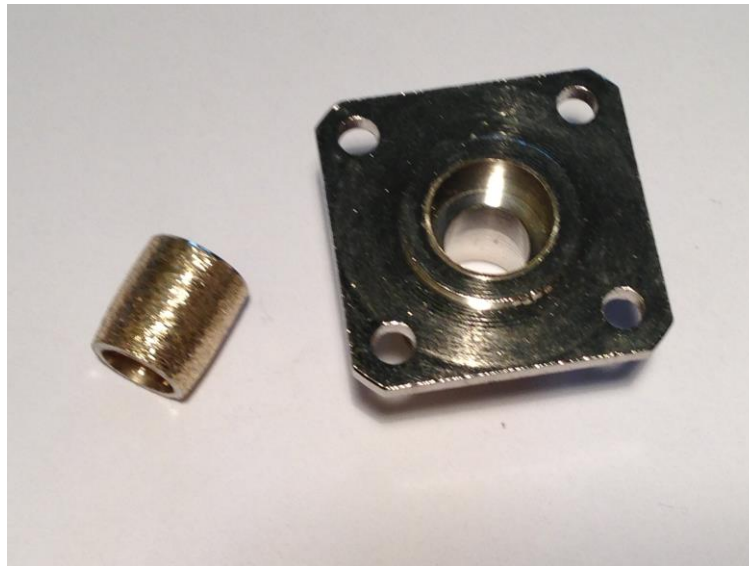
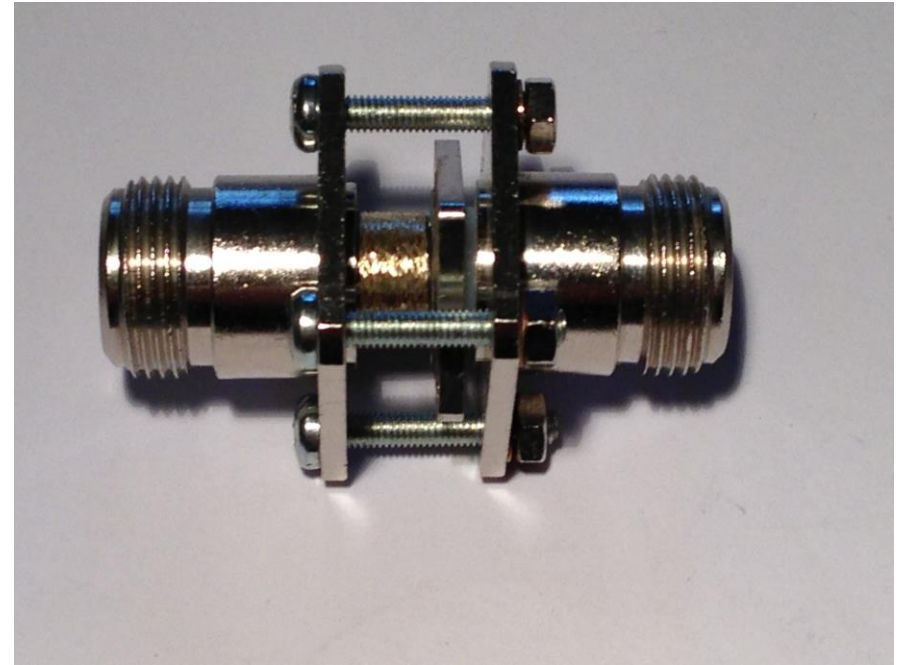

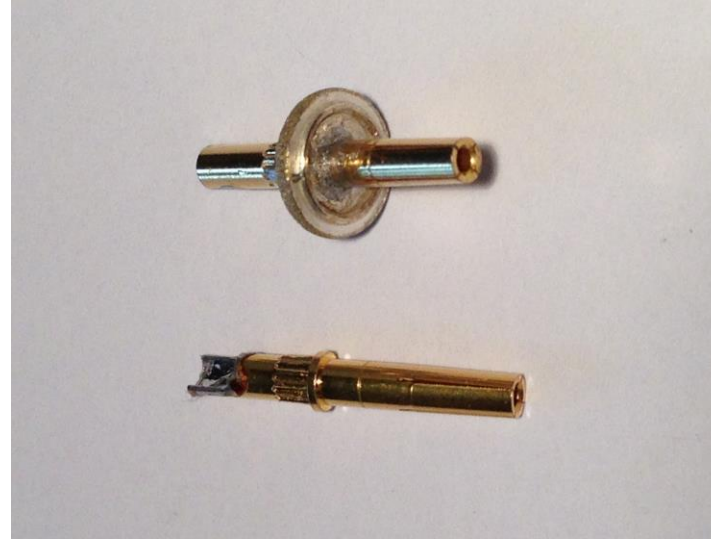

Pending the female adaptor you are going to use following dimensions are important to measure and note.

The reference plane is **9.12mm** from the front. You have to control and design the distance from the shorting disk to the reference plane. If the shorting disk is positioned where the PTFE went flush with the plane where the diameter of 7mm begins then the distance X is as on the drawing to the right. The negative delay in the calibration setting for the VNWA will be **X mm** multiplied by 3.3333... in ps and when entered in calibration settings it must be entered with double value due to a reflection.

If you can manage to design a shorting disk flush with the reference plane then the delay will be 0 ps.

In my case the distance is 14.6mm from the front and then the delay being  $(14.6-9.12)*3.3333.. = -18.27\text{ps}$ . **Yours will be different...**

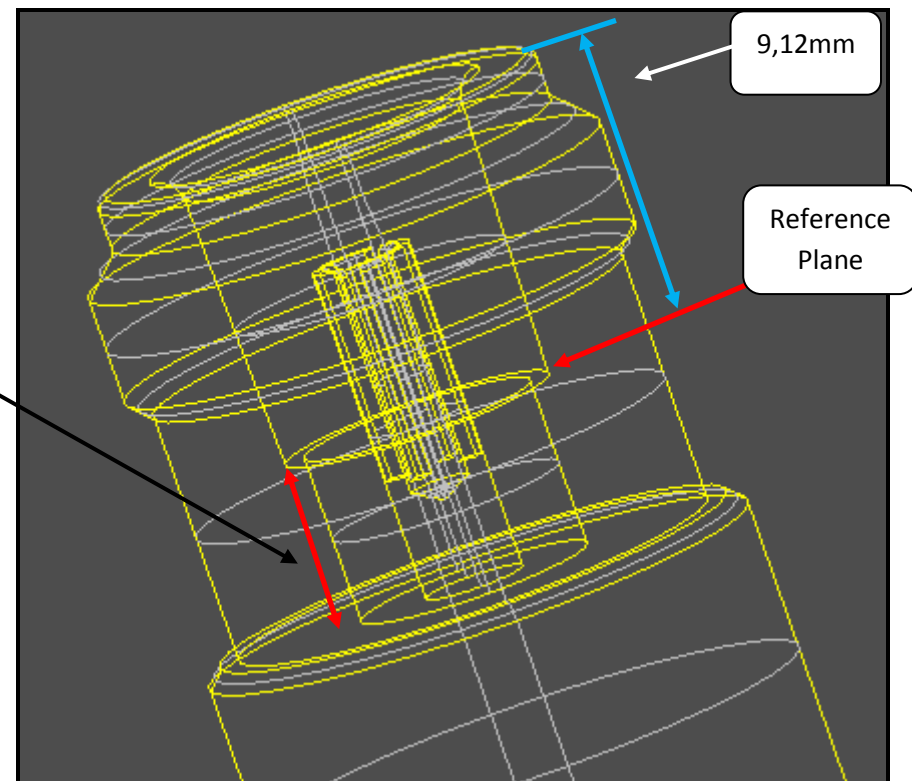

A note about detail picked up from the user manual of the HP 85032B/E calibration Kit.

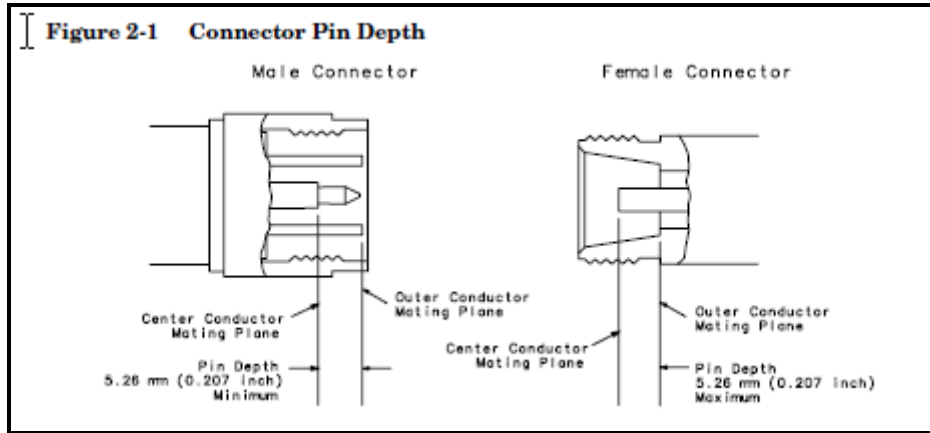

The center conductor for the male is indicated to be no further out than 5.26mm from the reference plane. As the dimension range for the mating male part is 5.33 to 5.88mm long, the tip will then be outside the reference plane by 0.07 to 0.42mm which is rarely seen. In most cases the tip is below the calibration plane by up to 0.5mm. In the simulations is used a recessed tip of 0.5 mm, specified by Radial as the only the only company specifying anything. The 3-dimensional drawing used in this document (from Huber Suhner) also indicate a recessed tip of 0.5mm.

Next section of this document will be a summary of all the calibration settings and followed by measurements with comparison to the two HP85032/E kit and the HP85032/BE clones using the center conductor extender.

As several persons is waiting for this document and I have other waiting activities for a couple of weeks I will release **this draft document** and invites comments and suggestion as well correction if you find errors.

Kind regards

Kurt

Februar 22 2014